

"TAIKO"

ROTARY PRESS

YMP-1300

YMP-1900

INSTRUCTIONS AND PARTS

MANUAL



TAIKO GIKEN CO, LTD.

980-15 Nakasaigou Gifu 〒501-1177 Japan

TEL:058-215-7801 FAX:058-215-7802

E-mail:taikogif@bronze.ocn.ne.jp

<http://www18.ocn.ne.jp/~taiko/>

Before Starting Up

Check all electrical connections for physical tightness , check to see no loose wires.

Check drive chains are around sprockets and that chain tension is not excessive or too loose.

Check chain lubrication, if dry, re-lubricate with a small quantity of heat resistant grease.

Check condition of machine: - drum, pressure rollers , belt, etc.

Set a metal plate for fusing (ref 102) on the front platform by screws.

Starting Up

Check pressure by adjusting two knobs (ref 101) with red line marking standard height. Pressure may require to be decreased for considerable thick materials or hemmed pieces and increased for considerable thin materials.

The blue knob (ref 100) on the top and at the back right hand side of the machine will turn automatically when the belt runs off, activating the motor (ref 58) in the control panel to realign the belt .

Set the temperature control thermostat (ref 56) to 250 deg. C . Adjustment of the temperature can be made depending on the material, operating speed and the quality of the crease or fusing that is required.

Set speed control (ref 55) at 5. Adjustment of speed can be made depending on the material.

Switch on the heater switch (ref 54) and drive motor switch (ref 51).

Note

It is possible that a new machine will smell hot for the first few minutes and smoke may even pass from the drum centre as it heats up out through the side of the control box.

When operational temprature is reached the temperature indicator lamp (ref 53) goes out.

Mounting the plate Die and Folders

In case of creasing, change a metal plate for fusing (ref 102) to a die mounting plate (ref 33) with folders which should be set on the front platform and secured with screws provided by drilling. Position the right and left hand folders to 3"- 6" apart (permits seperation on exit from machinel). The height and position of the folders must be such that their points have no contact with the dum, but when the work is fed through them it enters the nip of the belt and drum and is taken away smoothly. Once mounted the folders should be firmly secured. To change to die shape simply slacken the four screws holding the mounting plate and slot OFF.

Switch Off

Set a timer (ref 57) for 30 minutes and switch the heater switch (ref 54) and the motor switch (ref 51) to off. The machine will continue to run for the time pre-set on time (57).

Maintenance

Keep the belt and drum clean, check operation of self levelling motor and associated micro-switches, speed and temperature controls as a daily task. Check condition of the springs, chains, chain tensions, spring loaded bearings, etc., as a weekly task.

When greasing/lubricating chains, sprockets , etc., use heat resistant grease as a monthly task.

Belt changing

Switch Off Power and Unplug Machine

1. Remove brush (ref 104) and unloading tray (ref 105) as well as the metal plate for fusing (ref 102).
2. Unscrew the right hand pressure grip (ref 101) and the associated tension spring and the two screws holding down the top cover (ref 32) and remove the top cover.
3. Take out the lower front roller (ref 42) from the roller bearing bushes (ref 23 & 24).
4. Take out the top front roller (ref 41) by compressing the spring bearings and removing the roller to the left hand side.
5. Remove bottom centre roller (ref 41) as para. 4 above.
6. Remove bottom back roller (ref 41) as para. 4 above.
7. Remove top back roller (ref 41) as para. 4 above.
8. Loosen allen cap screw on right hand side of the rubber pressure roller spindle (ref 40) and also loosen the 5mm cross pein round head screw from the left hand side bearing housing and take out the rubber covered pressure roller (ref 39).
9. Slide belt out of machine taking care not to bend the fingers of the belt guidance switches (ref 106).
10. Replace new belt by carrying out the above instructions in reverse order.
11. When switching on check that the belt runs true and that the micro switch fingers (ref 106) activate the belt levelling motor (ref 58).

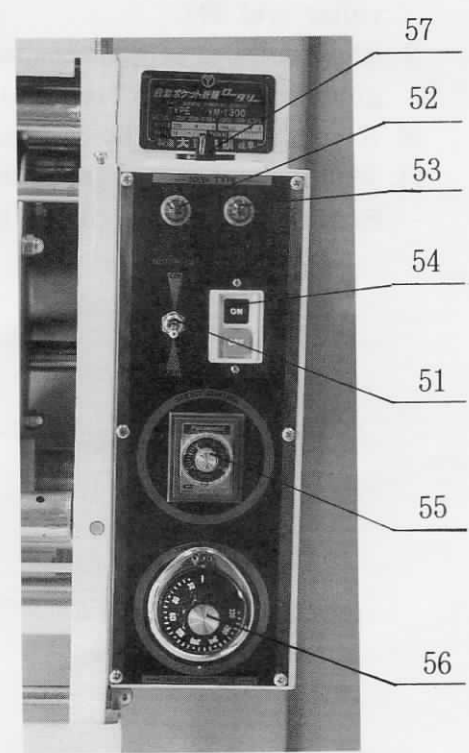
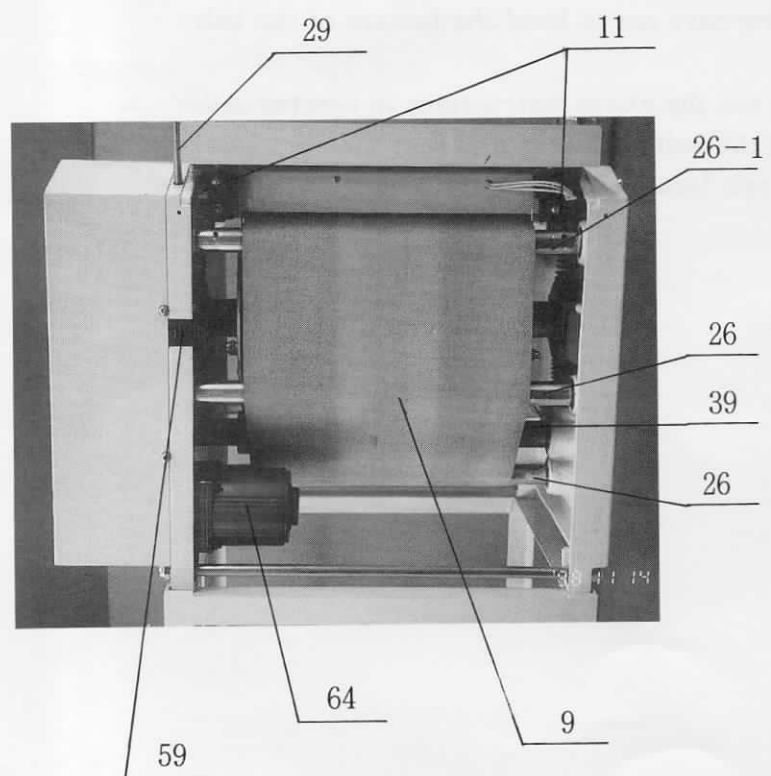
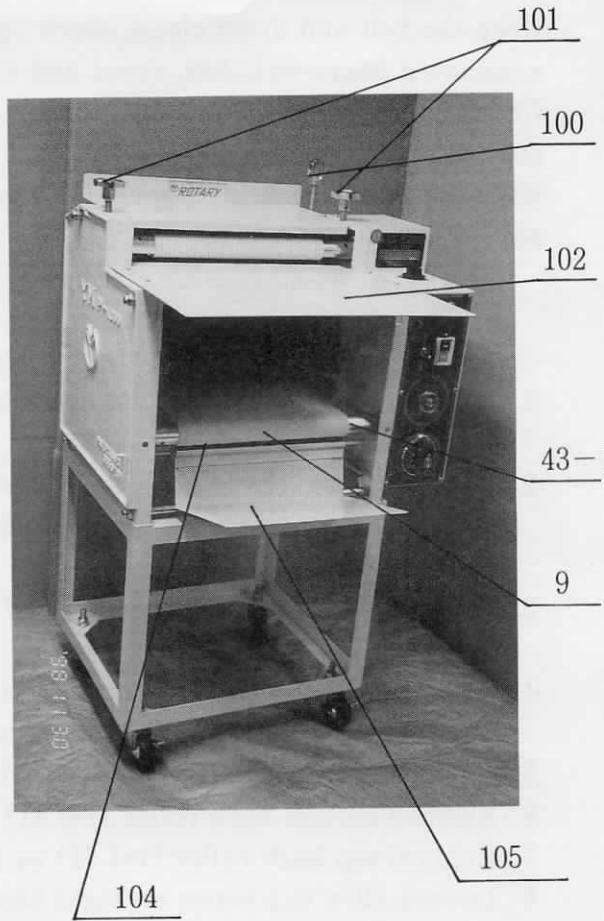
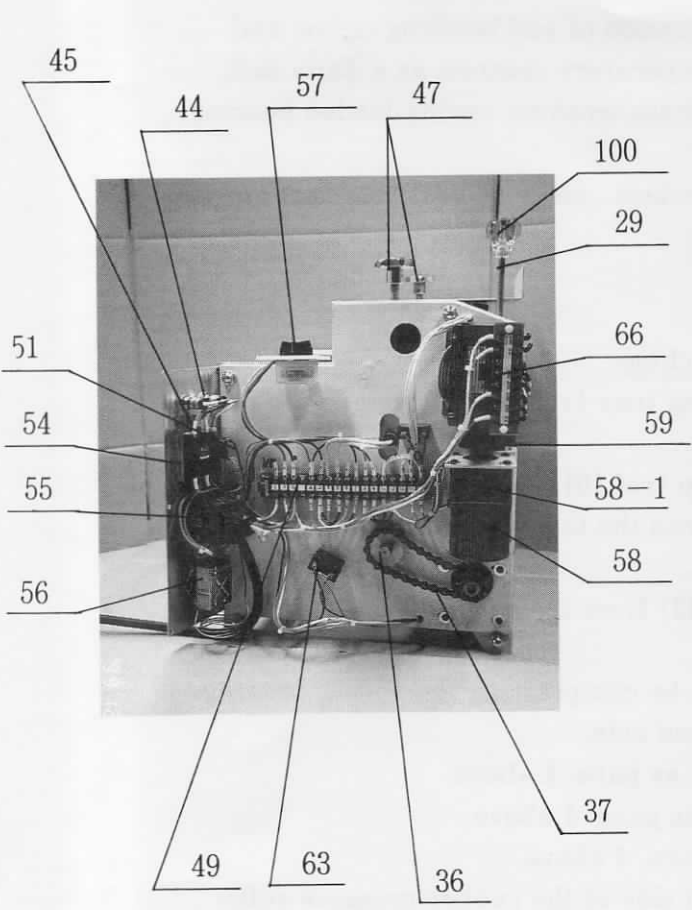

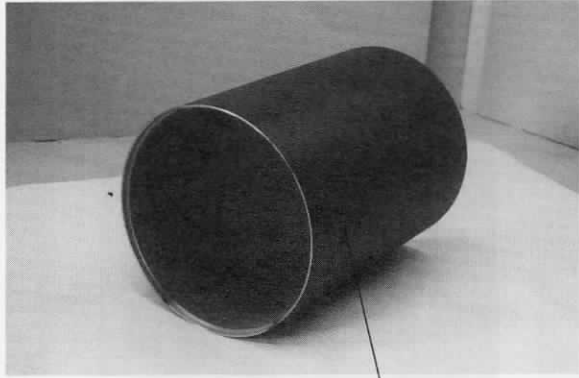

1

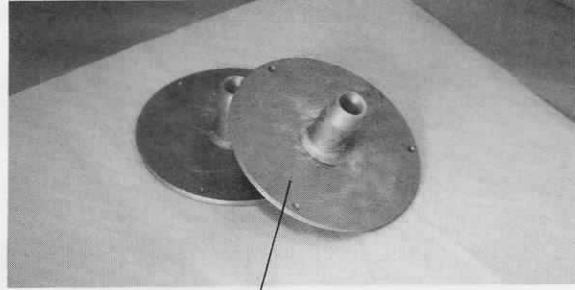

2

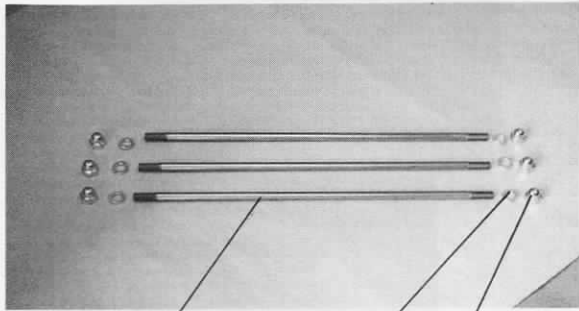

4

3-1

3

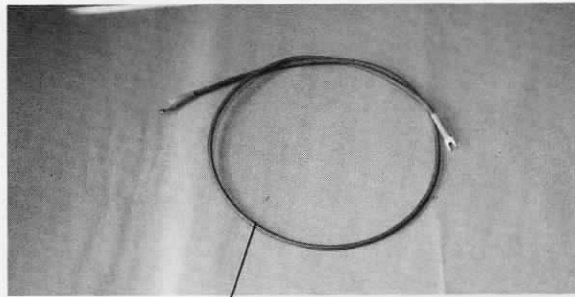

5-1

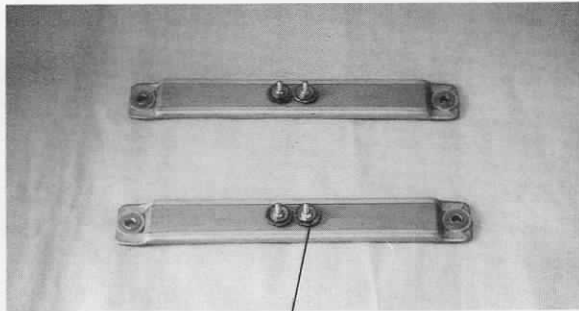

5

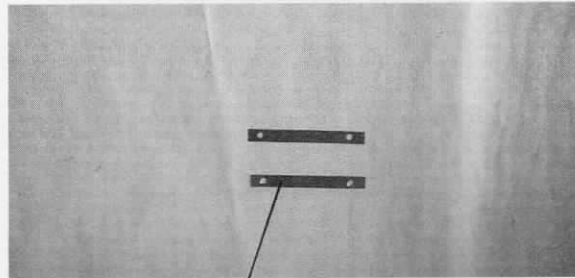

5-2

9

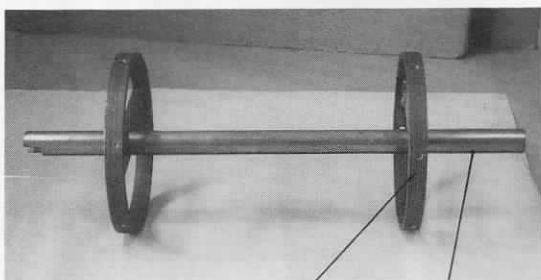

7

6

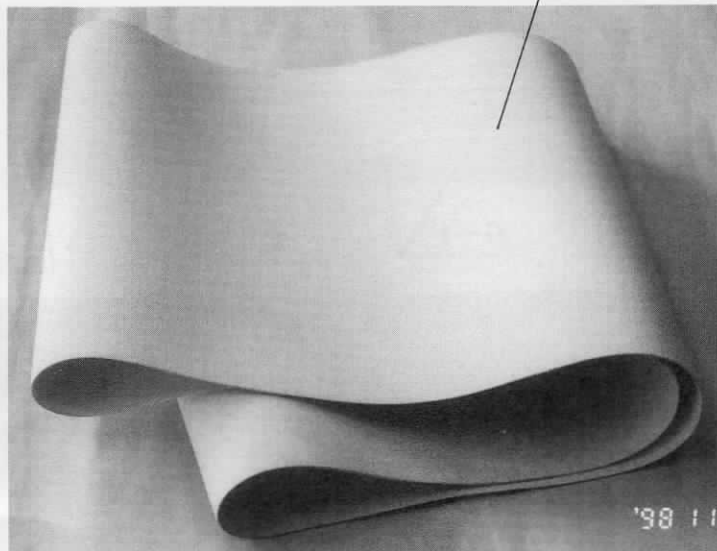

'98 11

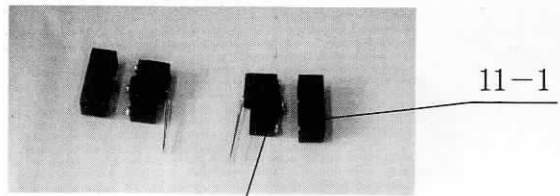

11

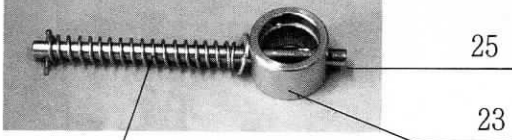
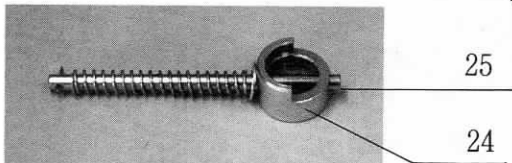
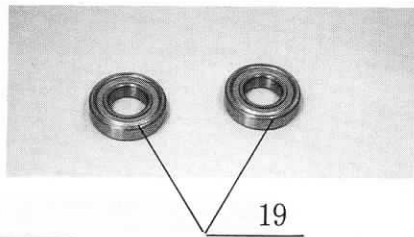

22

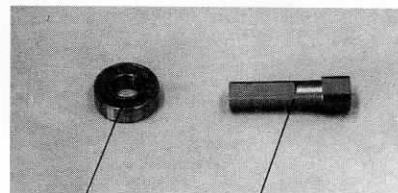
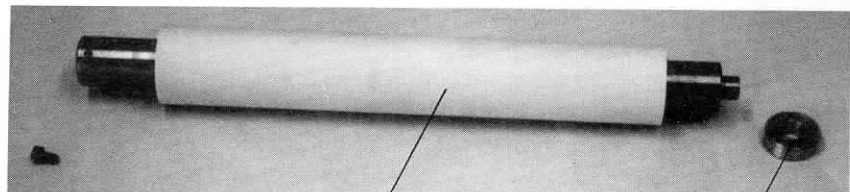
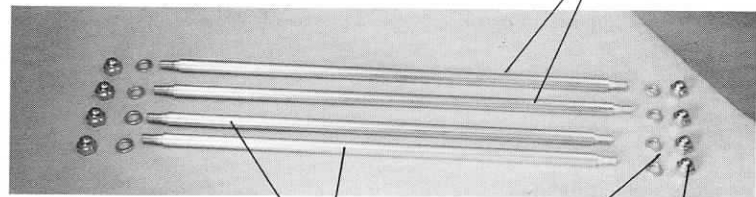
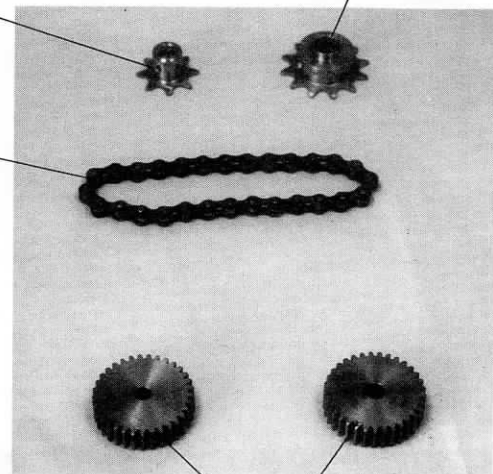
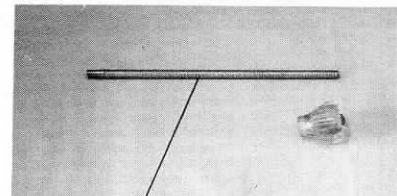
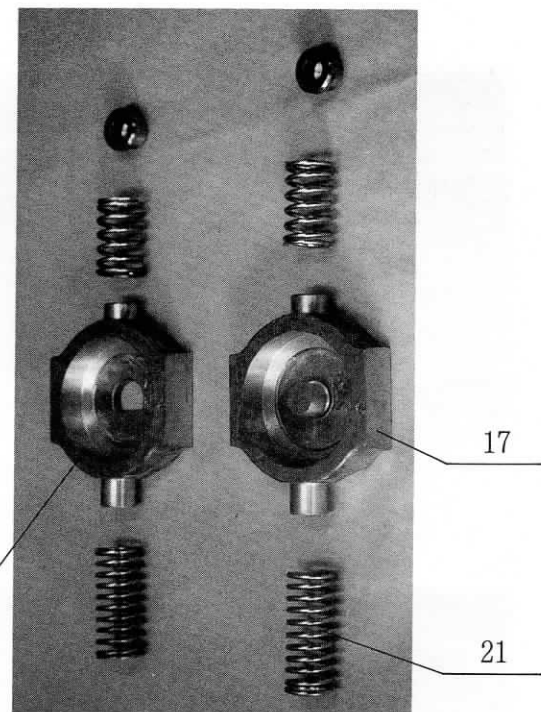
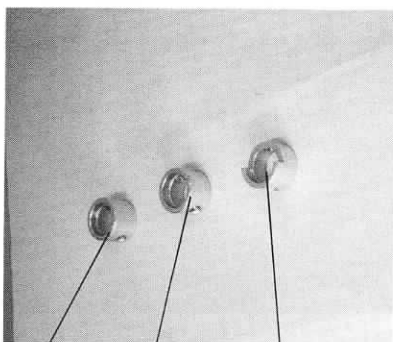

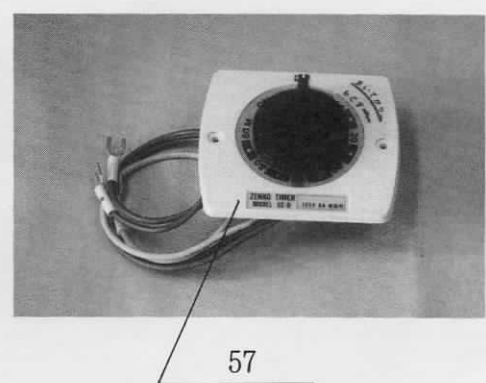
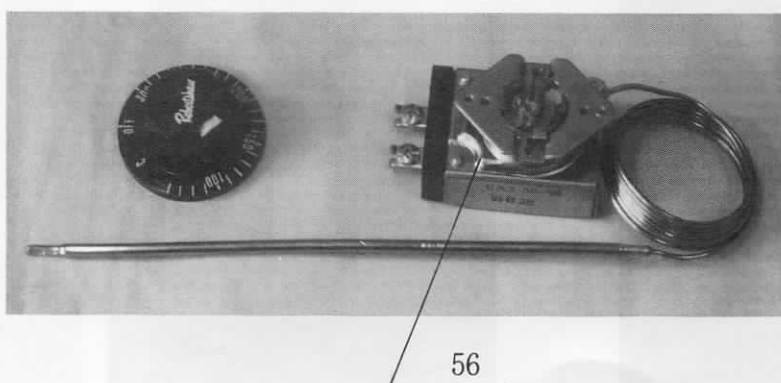
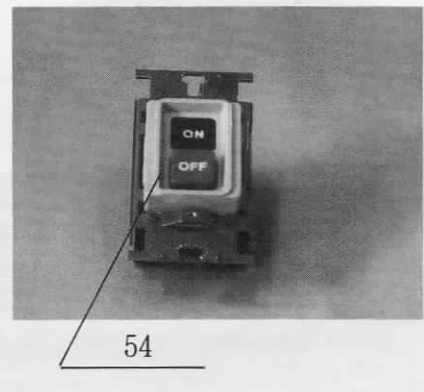
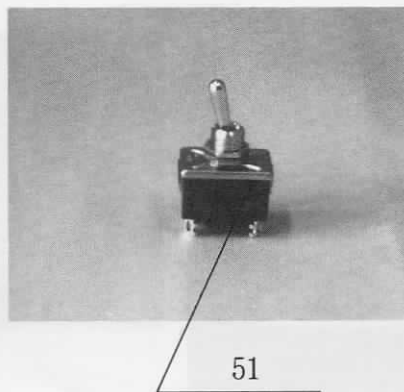
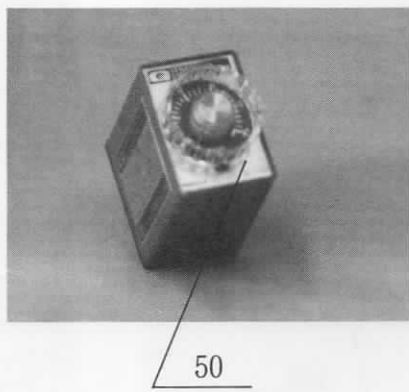
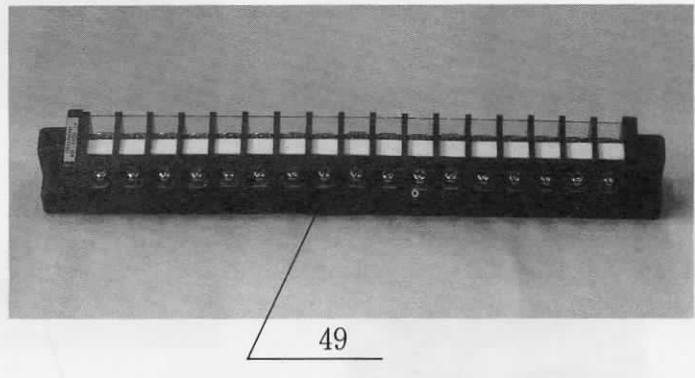
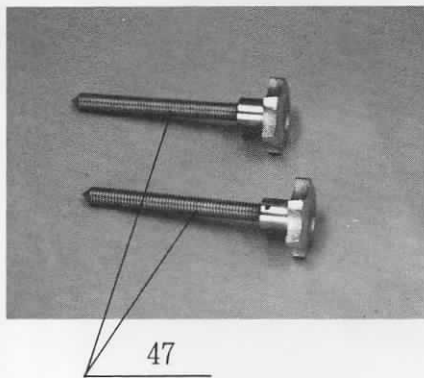
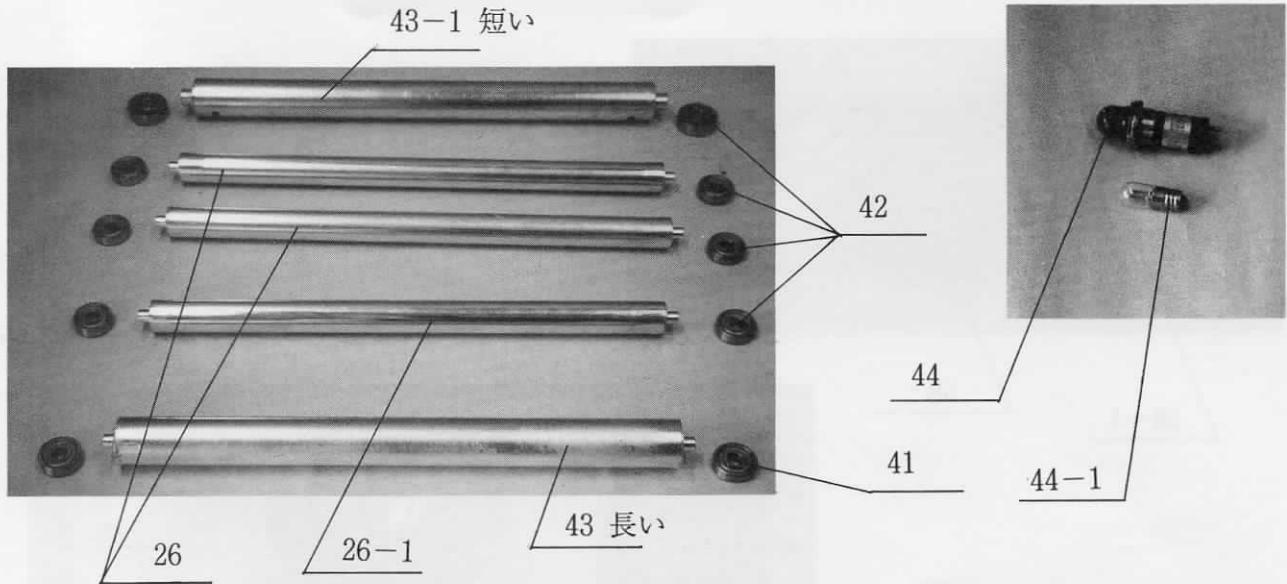

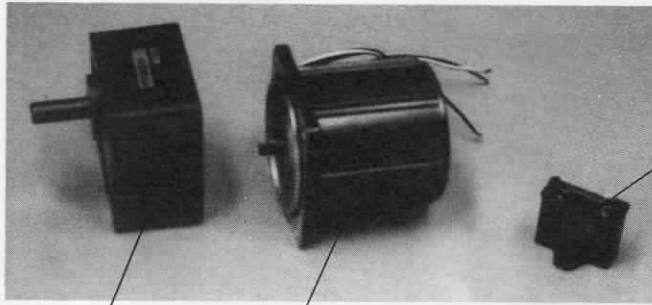

58-1

58

63-1

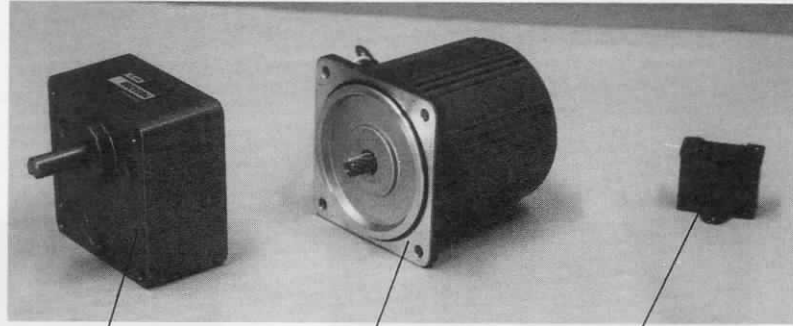

64-1

64

63



66

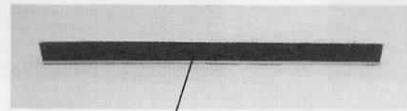

104

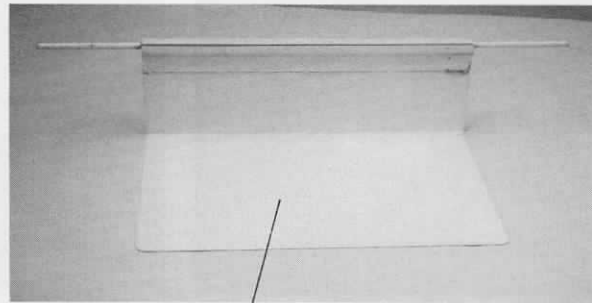

105



Parts List for YMP-1300 & 1900

Ref/Part No.	Description
1	Teflonised Drum
2	Drum Caps
3	5/16" Domed Nut.
3 - 1	Spring Washer
4	Drum Locking Spindle
5	Heating Element
5	Lead Wire
5 - 1	Lead plate
6	Shaft
7	Heating Element Mounting Ring
9	Silicon Belt
11	Levelling Micro Switch
11 - 1	Switch Cover
17	Bearing Block - Left
18	Bearing Block - Right
19	Ball Bearing 62072
21	Pressure Spring
22	Belt Tension Spring
23	Roller Bearing Bush - Left
24	Roller Bearing Bush - Right
25	Bush Holding Spindle
26	Roller 'B' Type
26 - 1	Roller 'B' Type (Short)
29	Levelling Indicator Spindle
30	3/8" Domed Nut
31	Frame Spindle
31 - 1	Frame Spindle (Short)
35	Drive Sprocket 8 T
36	Drive Sprocket 12T
37	Drive Chain
39	Rubber Covered Pressure Roller
40	Spindle
41	Ball Bearing 6202
42	Ball Bearing 6200
43	Roller 'A' Type
43 - 1	Roller 'A' Type (Short)

Ref/Part. No.	Description
44	Motor Lamp Holder
44-1	Motor Lamp
45	Heater Lamp Holder
45-1	Heater Lamp
47	Threaded Spindle for Pressure System
49	Connector Strip
50	Speed Control Box
51	Motor Switch
52	Indicator Lamp for Motor
53	Indicator Lamp for Heater
54	Heater Switch
56	Heat Regulator - Thermostat.
57	Timer for Cooling
58	Belt Levelling Motor
58-1	Motor Head
59	Belt Levelling Sprocket
63	Condenser
63-1	Condenser (Small)
64	Drive Motor
64-1	Motor Head
66	Transformer
100	Levelling Indicator Knob
101	Pressure Adjusting Grips
102	Metal Plate for Fusing
104	Brush
105	Tray

Pocket Folder (Option)

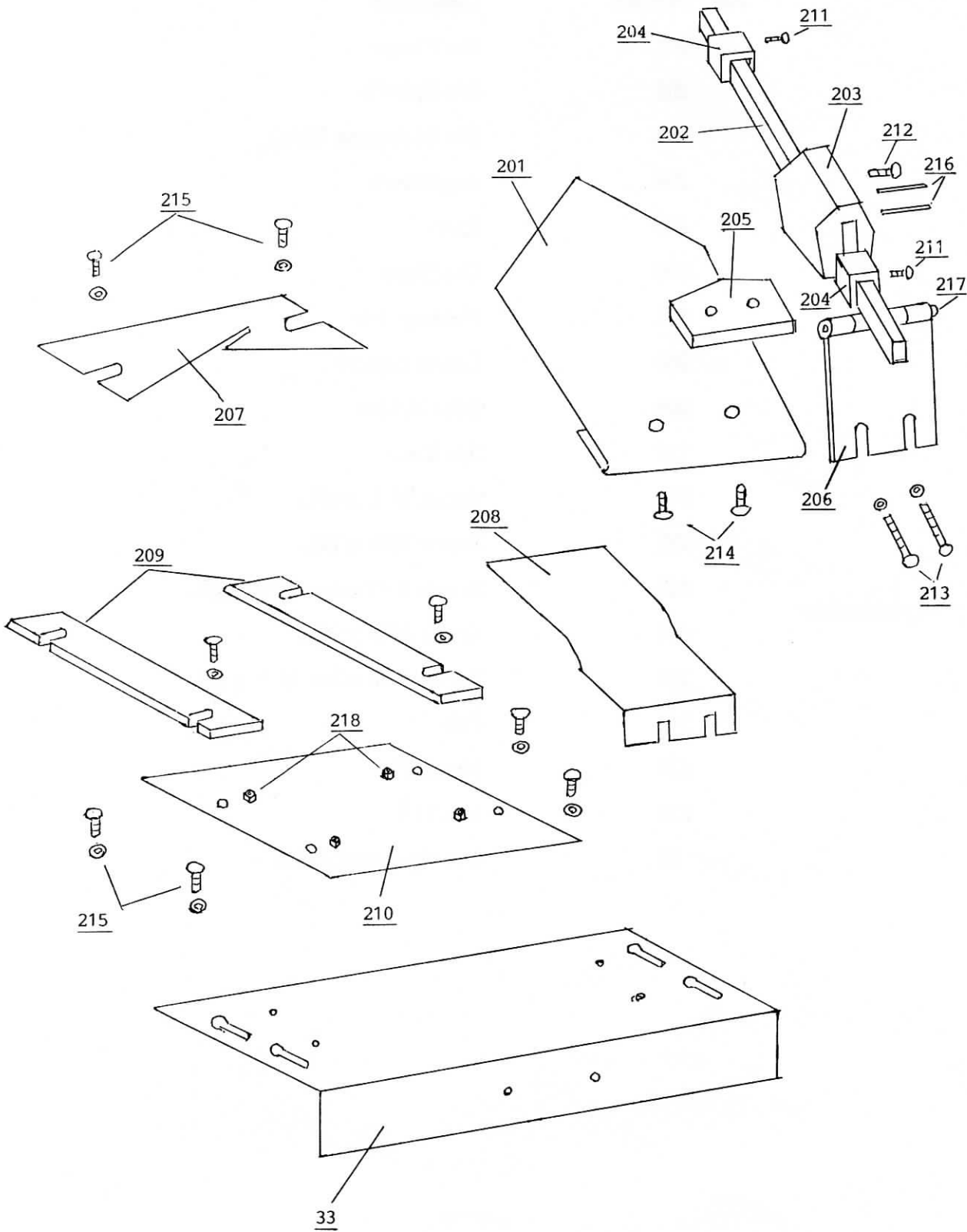

Part List for Pocket Folder

Ref/Part No.	Description
201	Die Shape
202	Die Spindle
203	Die Mounting Block
204	Stop Block
205	Base
206	Die Hinge
207	Folding Toe
208	Lower Spacer
209	Side Guides
210	Die Base
211	Screw M 4 x 10L
212	Screw M 6 x 20L
213	Screw & Washer M 5 x 25L
214	Screw M 5 x 15L
215	Screw & Washer M 5 x 15L
216	Pin
217	Hinge Pin
218	Nut M 6
33	Die Mounting Plate

Operation of Pocket Creasing

1.

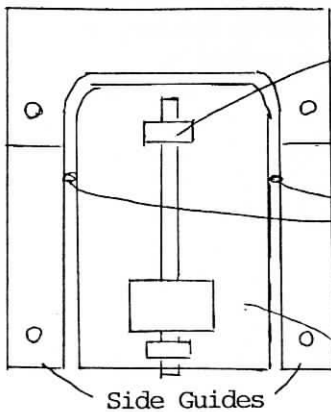

Adjust and Secure the Stop Block (ref 204) by Screw (ref 211) to the suitable point where the piece of fabric is pulled in automatically.

Leave the space between Side Guides (ref 209) and Die Shape (ref 201) depending on the fabric's thickness creased.

2.

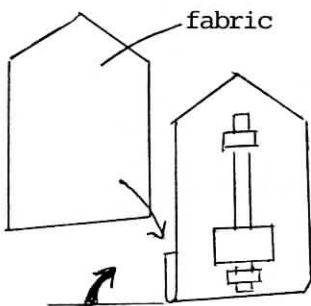

A) Raise up the Die Shape this side and put the piece of fabric in the hollow of the back side.

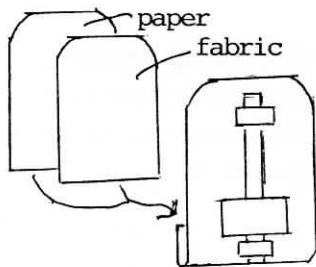

B) In case of round shape such as Die Shape E, attach a paper of same form to the piece of fabric in order to make round shape successfully.

3.

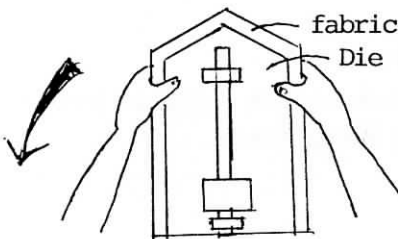

Hold both the piece of fabric (with paper) and the Die Shape at the upper position and down as it is.

4. parallel sides line

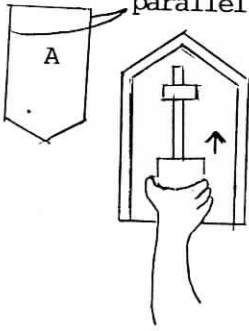

A) In case of standard shape such as Die Shape A ;

Push the Die Mounting Block (ref 203) ahead until the Stop Block contacts the stopper, i.e. the piece of fabric is pulled in automatically.

C slanting sides line

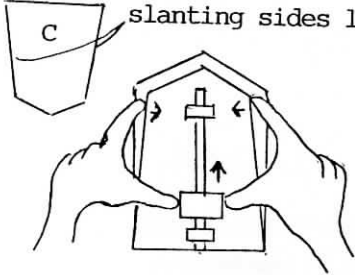

B) In case of Die Shape C :

Push the Die Mounting Block ahead by thumbs as pressing the piece of fabric's edge (corner) inside by forefingers.

E round shape

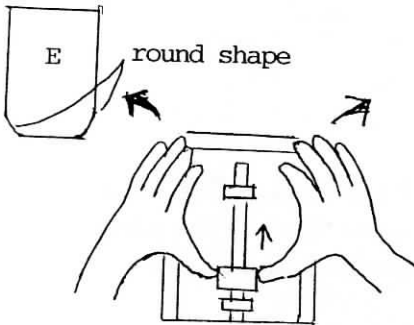

C) In case of round shape such as Die Shape E ;

Push the Die Mounting Block ahead by thumbs as spreading out the edges (corners) outside by forefingers/middle fingers/third fingers until the edges are pulled in.

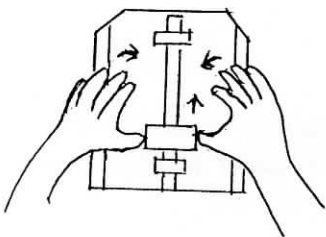

Then press both sides edges inside as pushing the Die Mounting Block ahead.

Examples of Die Shapes

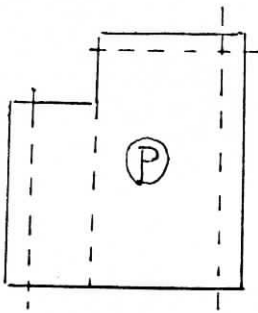
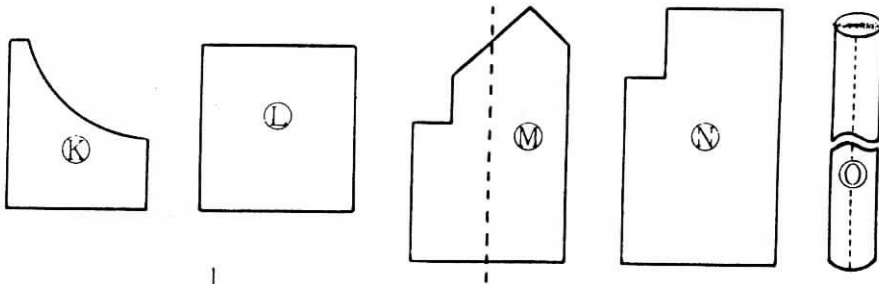
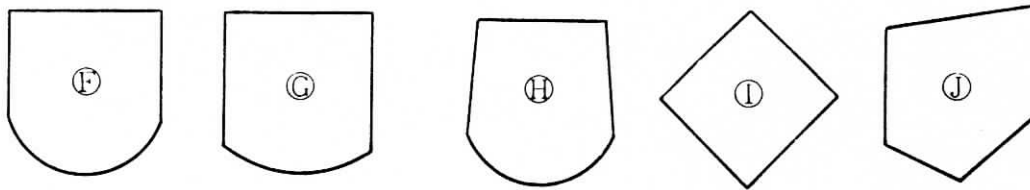
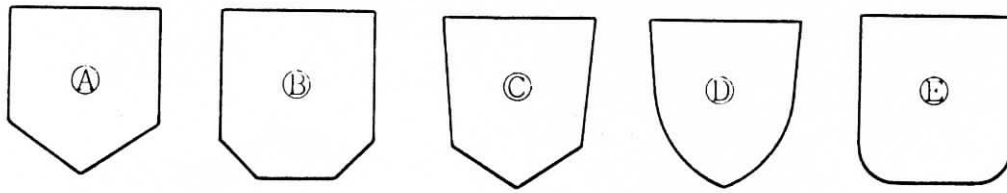

* Die Shapes A to L for pocket, M & N for side sleeve, O for waistband and P for shirt front.

* Any other Die Shapes are available according to your request.